



3-Channel Low-Power EDTV/SDTV Video Line Driver With Low-Pass Filters

FEATURES

- Single Supply: 2.85 V to 5 V
- Low Total Supply Current = 4.5 mA (max)
- Low Power Mode: 5 μ W (max)
- Integrated DAC Reconstruction Filters
- Video Line Driver Outputs with 6 dB Gain
- Rail-to-Rail Output
- RoHS Compliant 9-Pin Wafer Scale Package

APPLICATIONS

- Personal Media Players
- Digital Cameras
- Cellular Phone Video Output Buffering
- USB/Portable Low Power Video Buffering

DESCRIPTION

The THS7318 is a very low power single-supply 3 channel device designed to process Y' , P'_B , P'_R enhanced definition TV and Y' , C' , and CVBS standard definition TV signals. It integrates circuitry to perform signal processing commonly required in video output applications.

All channels incorporate 3rd-order 20-MHz Butterworth DAC reconstruction filters designed for video systems with 54 MSPS DAC sampling rates like NTSC/PAL 480p/576p EDTV and 480i/576i SDTV video.

Rail-to-Rail output drivers on all channels allow for both ac and dc coupled outputs.

The low quiescent current makes it an excellent choice for USB powered or portable video applications.

The THS7318 is available in a 9-pin NanoFree™ wafer scale package. It is specified for operation from -40°C to $+85^{\circ}\text{C}$.

THS7318 BLOCK DIAGRAM

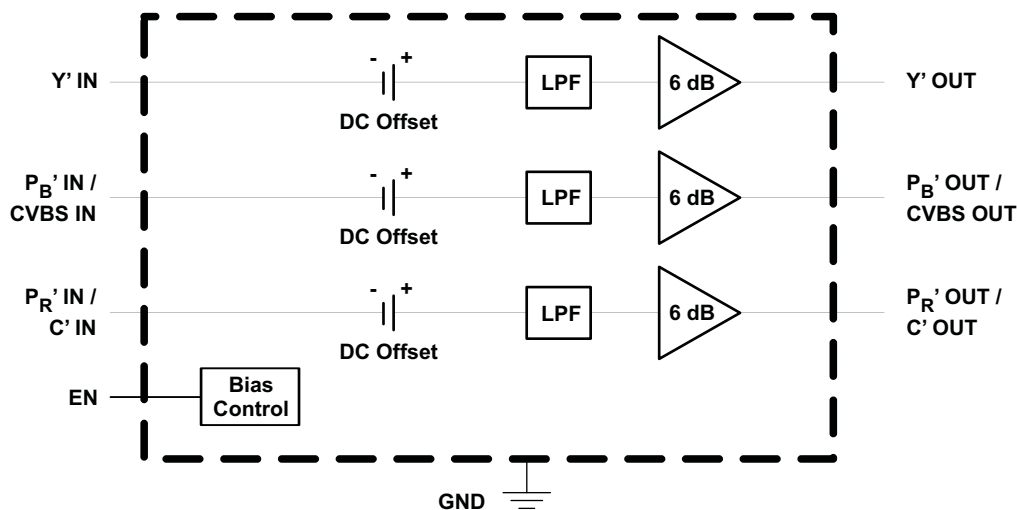

Please be aware that an important notice concerning availability, standard warranty, and use in critical applications of Texas Instruments semiconductor products and disclaimers thereto appears at the end of this data sheet.

NanoFree is a trademark of Texas Instruments.



This integrated circuit can be damaged by ESD. Texas Instruments recommends that all integrated circuits be handled with appropriate precautions. Failure to observe proper handling and installation procedures can cause damage.

ESD damage can range from subtle performance degradation to complete device failure. Precision integrated circuits may be more susceptible to damage because very small parametric changes could cause the device not to meet its published specifications.

ABSOLUTE MAXIMUM RATINGS

over operating free-air temperature range (unless otherwise noted)⁽¹⁾

		VALUE	UNIT	
V_{SS}	Supply voltage, V_{S+} to GND	5.5	V	
V_I	Input voltage	-0.4 to V_{S+}	V	
I_O	Output current	± 100	mA	
Continuous power dissipation		See Dissipation Rating Table		
T_J	Maximum junction temperature	Any condition ⁽²⁾	150	$^{\circ}\text{C}$
		Continuous operation, long term reliability ⁽³⁾	125	$^{\circ}\text{C}$
T_{stg}	Storage temperature range	-65 to 150	$^{\circ}\text{C}$	
T_A	Ambient operating temperature range	-40 to 85	$^{\circ}\text{C}$	
ESD ratings	HBM	2000	V	
	CDM	1500	V	
	MM	200	V	

(1) Stresses above those listed under *absolute maximum ratings* may cause permanent damage to the device. These are stress ratings only and functional operation of the device at these or any other conditions beyond those indicated under *recommended operating conditions* is not implied. Exposure to absolute maximum rated conditions for extended periods may degrade device reliability.

(2) The absolute maximum junction temperature under any condition is limited by the constraints of the silicon process.

(3) The absolute maximum junction temperature for continuous operation is limited by the package constraints. Operation above this temperature may result in reduced reliability and/or lifetime of the device.

DISSIPATION RATINGS⁽¹⁾

PACKAGE	θ_{JC} ($^{\circ}\text{C}/\text{W}$)	θ_{JA} ($^{\circ}\text{C}/\text{W}$)	POWER RATING ⁽²⁾ ($T_J = 125^{\circ}\text{C}$)	
			$T_A = 25^{\circ}\text{C}$	$T_A = 70^{\circ}\text{C}$
YZF	38	105	950 mW	428 mW

(1) This data was taken with the JEDEC High-K test PCB.

(2) Power rating is determined with a junction temperature of 125°C . This is the point where distortion starts to substantially increase and long-term reliability starts to be reduced. Thermal management of the final PCB should strive to keep the junction temperature at or below 125°C for best performance and reliability.

RECOMMENDED OPERATING CONDITIONS

over operating free-air temperature range (unless otherwise noted)

		MIN	MAX	UNIT
V_{S+}	Supply voltage	2.85	5	V

PACKAGING/ORDERING INFORMATION

PACKAGED DEVICES	PACKAGE TYPE ⁽¹⁾	PART CODE	TRANSPORT MEDIA, QUANTITY
THS7318YZFT	Wafer Scale 9-pin	BYR	Tape and Reel, 250
THS7318YZFR			Tape and Reel, 3000

(1) For the most current package and ordering information, see the Package Option Addendum at the end of this document, or see the TI Web site at www.ti.com.

NanoFree™ Placement and Removal Procedures

These procedures are generic guidelines to rework NanoFree™ packages assembled on a 0.056-inch thick FR4 board. It's recommended to modify heating profiles for different board thicknesses and equipment used. The assembly process recommended below should be used with a new device. Do not reuse the part after it is removed.

Air-Vac Engineering (www.air-vac-eng.com) has established NanoFree™ reflow profiles for their Hot Gas (convection) rework equipment DRS-24NC. The NMX090DVG nozzle is recommended for use with the YZF package. Customers can use other comparable hot gas (convection) equipment and tooling.

Placement

1. Apply flux paste to component
2. Align device over pads
3. Place device on board. Care must be taken to prevent over-travel during placement which may damage the part or vacuum tip.
4. Raise nozzle 0.05"
5. Preheat board to 90°C, nozzle warming up 20% air flow, 125°C
6. Soak Stage—20% air flow, 225°C, 90 seconds
7. Ramp Stage—20% air flow, 335°C, 30 seconds
8. Reflow Stage—25% air flow, 370°C, 65 seconds
9. Cool down Stage—40% air flow, 25°C, 50 seconds

Removal

1. Apply flux paste to component
2. Align Nozzle over part to be removed
3. Maintain nozzle 0.050" over device. Care must be taken to prevent over-travel of the vacuum tip which may damage the part or vacuum tip when measuring this distance.
4. Preheat board to 90°C, nozzle warming up 20% air flow, 125°C
5. Soak Stage—20% air flow, 225°C, 90 seconds
6. Ramp Stage—20% air flow, 335°C, 30 seconds
7. Reflow Stage—25% air flow, 370°C, 65 seconds
8. Enable Vacuum at the end of the reflow cycle, lower vacuum nozzle, and remove part
9. Cool down Stage—40% air flow, 25°C, 50 seconds
10. Turn off the vacuum and remove part from nozzle.
11. Care should be used if the device is to be returned to TI for failure analysis. Using any metal tweezers or rough handling can damage the part, and render it un-analyzable.

ELECTRICAL CHARACTERISTICS

$V_{S+} = 3.3V$, $27^{\circ}C$, Y' and P_R' / C' channels: $R_L = 150 \Omega$ and $C_L = 6.2 \text{ pF}$ to GND P_B' / CVBS channel: 75Ω and $C_L = 6.2 \text{ pF}$ to GND (unless otherwise noted)

PARAMETER		TEST CONDITIONS	MIN	TYP	MAX	UNIT	TEST LEVEL ⁽¹⁾
DC CHARACTERISTICS							
V _{SS}	Supply voltage range		2.85	3.3	5	V	B
I _Q	Quiescent supply current	EN = High	2.8	3.5	4.5	mA	A
V _{SD}	Shutdown supply current	EN = Low		0.150	<1	μA	A
	Output DC level shift voltage	All channels	110	150	200	mV	A
	Input bias current	Y' and P _B ' / CVBS channels	-100	-160	-240	nA	A
		P _R ' / C' channel	-170	-280	-415	nA	A
	Input resistance / capacitance			2.4/1		MΩ/pF	C
	Voltage gain		1.98	2	2.02	V/V	A
	Channel to Channel Gain Match	All Channels		±0.14	±1	%	A
PSRR	Power supply rejection	DC	47			dB	A
V _{OH}	Output voltage swing high	Y' and P _R ' / C' channel, 150 Ω to GND	2.85	2.96		V	A
		P _B ' / CVBS channel, 50 Ω to GND	2.6	2.9		V	A
	P _B ' output high minus output offset	At V _{S+} = 3.135 V, P _B ' / CVBS channel, 50 Ω to GND	2.3	2.65		V	A
	Output short-circuit current	Y' and P _R ' / C' channel		70		mA	C
		P _B ' / CVBS channel		100		mA	C
	Max current into EN pin	EN = Low			<1	μA	A
		EN = High			<1	μA	A
	Disable threshold	Low = off			0.6	V	A
	Enable threshold	High = on	2.1			V	A
	Output impedance in shutdown	EN = Low		20		kΩ	C
AC PERFORMANCE							
	0.1 dB Bandwidth	Relative to 1 MHz		11		MHz	C
	±1.0 dB Bandwidth	Relative to 1 MHz	14	17		MHz	A
	-3 dB Bandwidth	Relative to 1 MHz	17	20		MHz	B
	Normalized stop band gain	f = 43 MHz, Relative to 1 MHz		-21	-12	dB	A
	Differential gain	NTSC and PAL		0.05		%	C
	Differential phase	NTSC and PAL		0.03		deg	C
	Group delay variation	f = 11 MHz w/ref to 1 MHz		4		ns	C
	Signal to noise ratio	V _{OUT} = 2-V _{PP} sine wave		62		dB	C
t _r /t _f	Rise / fall time	V _{OUT} = 2-V step		20		ns	C
	Positive/ negative slew rate	V _{OUT} = 2-V step		80		V/μs	C
	THD at 1MHz	At 1MHz, 2 V _{PP}		73		dBc	C

(1) Test levels:

- A) 100% tested at 25°C. Over-temperature limits set by characterization and simulation.
- B) Limits set by characterization and simulation.
- C) Typical value only for information.

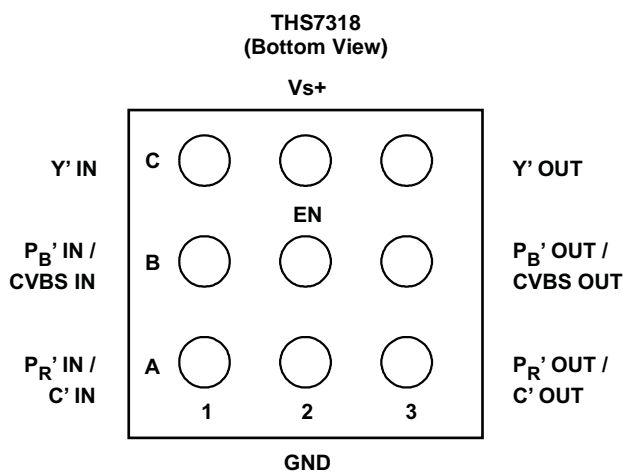
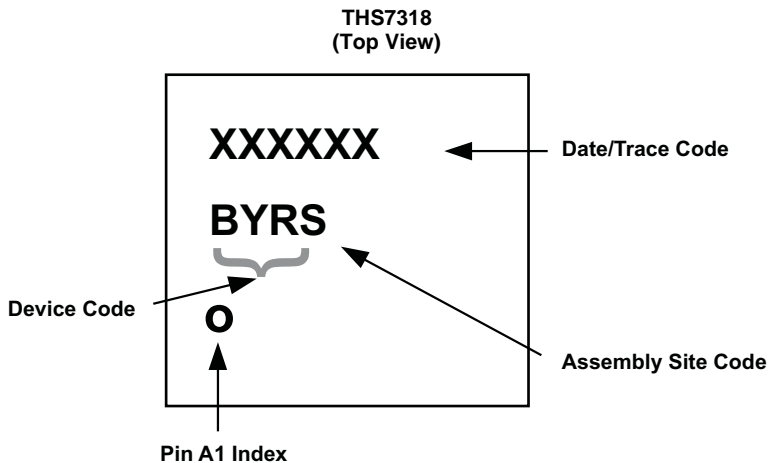

TERMINAL FUNCTIONS

COL.	ROW	PIN NAME	DESCRIPTION
1	C	Y' IN	Luma input
1	B	P _B ' IN / CVBS IN	Component video input / composite video input
1	A	P _R ' IN / C' IN	Component video input / chroma input
2	C	V _{s+}	Positive power supply input
2	B	EN	Enable input. Logic high enables part. Logic low disables part. To insure proper operation, this pin must be driven and cannot be left floating.
2	A	GND	Ground reference pin for all internal circuitry
3	C	Y' OUT	Luma output
3	B	P _B ' OUT / CVBS OUT	Component video output / composite video output
3	A	P _R ' OUT / C' OUT	Component video output / chroma output

THS7318 DESCRIPTION

The THS7318 is an integrated analog video processor designed with integrated Butterworth filters and video line driver amplifiers to provide the analog signal conditioning required for EDTV signals in portable video applications.

The device accepts 3 inputs; Y' (Luma), $P'_B / CVBS$ (analog color difference with blue emphasis / composite video) and P'_R / C' (analog color difference with red emphasis / chroma), and provides 3 filtered and amplified outputs; Y' , $P'_B / CVBS$ and P'_R / C' .

The following are detailed descriptions of each channel.

CHANNEL DESCRIPTIONS

All channels are comprised of DC offset, 3rd order Butterworth low pass filter, and output buffer amplifier. All channels are same except the Y' and P'_R / C' output amplifiers are designed to drive one doubly terminated 75 Ω video line and the $P'_B / CVBS$ output amplifier is designed to drive two doubly terminated 75 Ω video lines. Even under the fault condition where one of the video lines is shorted, the $P'_B / CVBS$ output amplifier is capable of full video performance on the properly terminated output.

DC Offset

The DC offset circuit is used to insure the output is not driven into saturation and video signal is not compressed. The nominal output offset caused by this circuit is 150 mV.

3rd Order Butterworth Low Pass Filter

To reduce DAC images that cause aberrations in the video display, a 3rd order Butterworth low pass filter is inserted in the signal path. This DAC reconstruction filter is designed for video systems with 54 MSPS DAC sampling rates like NTSC/PAL 480p/576p EDTV and 480i/576i SDTV video, with nominal 0.1-dB flatness to 11 MHz, -3-dB bandwidth of 20 MHz, and 20 dB attenuation at 43 MHz.

Output Buffer Amplifier

The output buffer amplifiers are designed for a gain of 6 dB. The Y' and P'_R / C' output amplifiers are designed to drive one doubly terminated 75 Ω video line and the $P'_B / CVBS$ output amplifier is designed to drive two doubly terminated 75 Ω video lines. Even under the fault condition where one of the video lines is shorted, the $P'_B / CVBS$ output amplifier is capable of full video performance on the properly terminated output.

TYPICAL APPLICATION CIRCUITS

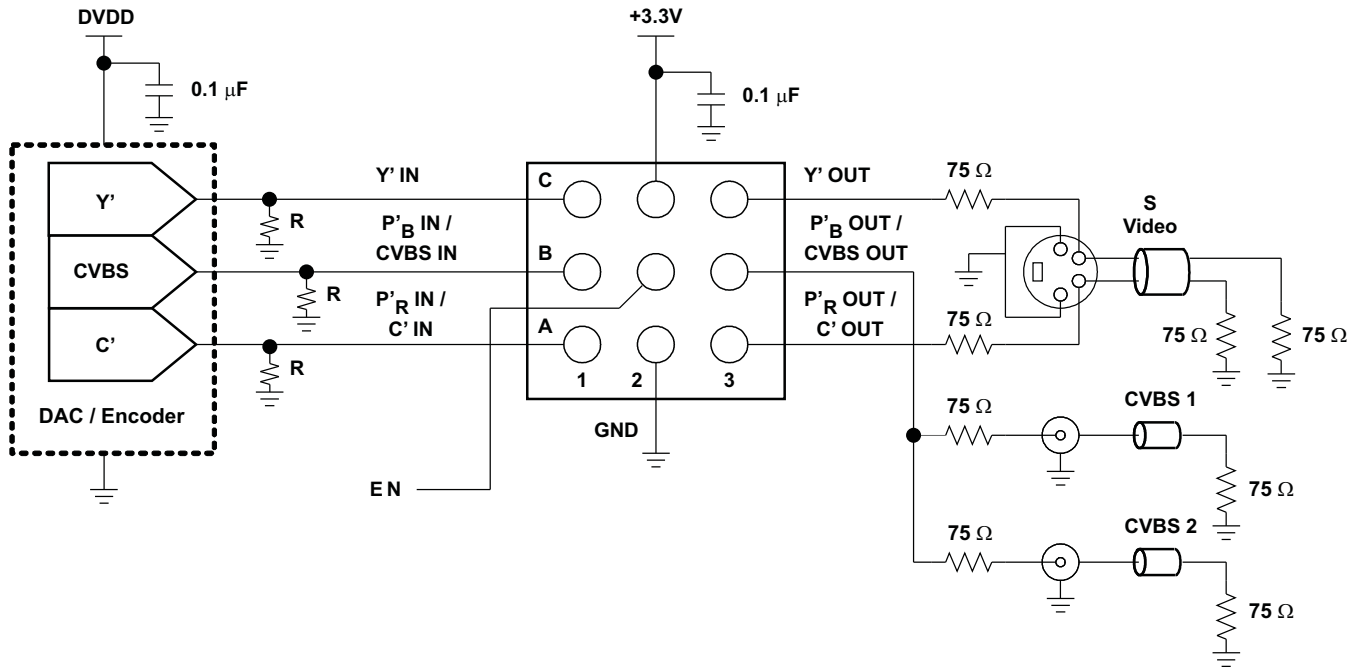

Figure 1. Application Drawing CVBS and S Video

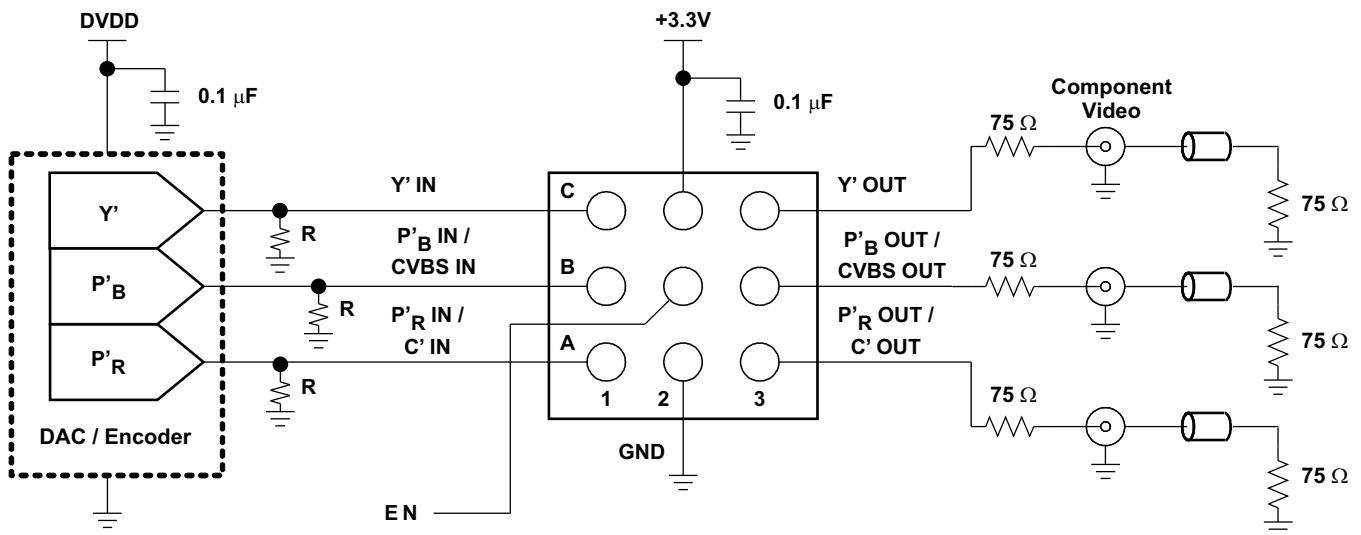
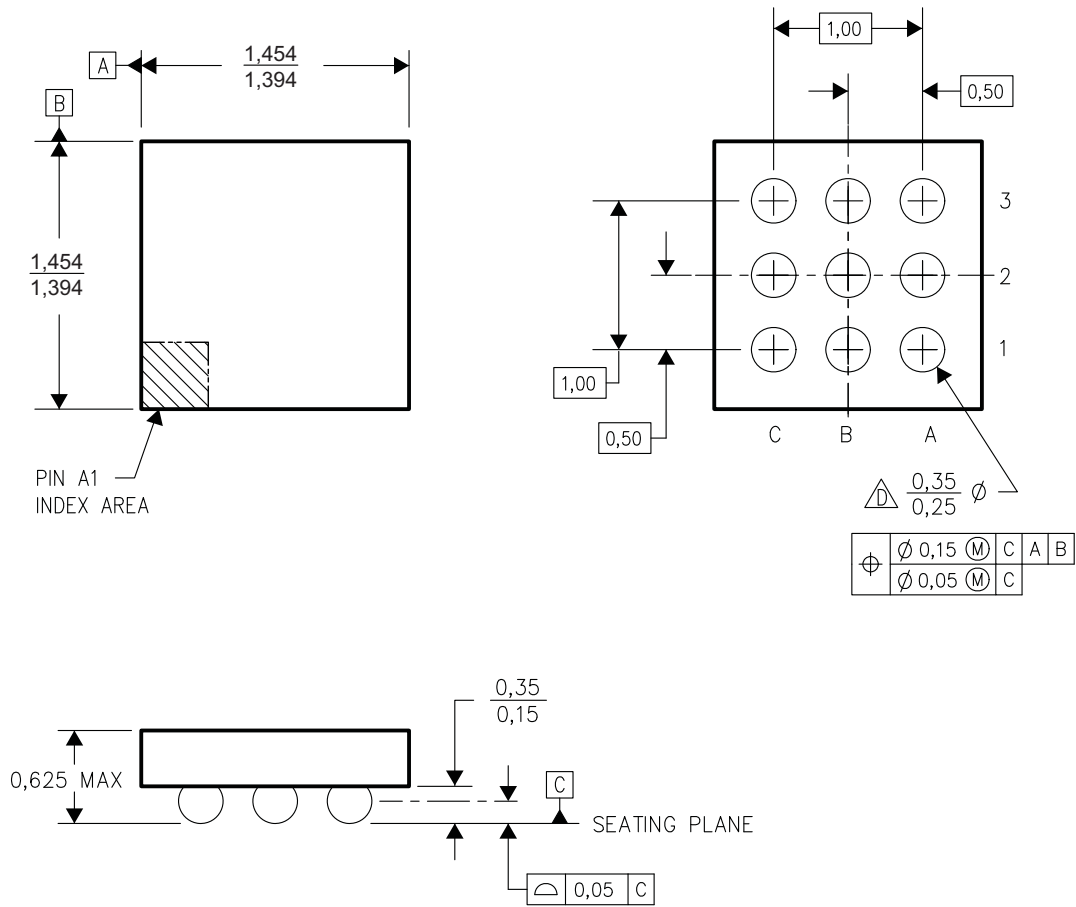

Figure 2. Application Drawing Component Video

MECHANICAL DATA



- NOTES:
- A. All linear dimensions are in millimeters.
 - B. This drawing is subject to change without notice.
 - C. NanoFree™ package configuration.
 - D. Reference Product Data Sheet for array population. 3 x 3 matrix pattern is shown for illustration only.
 - E. This package contains lead-free balls. Refer to YEF (Drawing #4204181) for tin-lead (SnPb) balls.

Figure 3. YZF Ball Grid Array Package Dimensions (in mm)

PACKAGING INFORMATION

Orderable Device	Status ⁽¹⁾	Package Type	Package Drawing	Pins	Package Qty	Eco Plan ⁽²⁾	Lead/Ball Finish	MSL Peak Temp ⁽³⁾
THS7318YZFR	ACTIVE	DSBGA	YZF	9	3000	Green (RoHS & no Sb/Br)	SnAgCu	Level-1-260C-UNLIM
THS7318YZFT	ACTIVE	DSBGA	YZF	9	250	Green (RoHS & no Sb/Br)	SnAgCu	Level-1-260C-UNLIM

⁽¹⁾ The marketing status values are defined as follows:

ACTIVE: Product device recommended for new designs.

LIFEBUY: TI has announced that the device will be discontinued, and a lifetime-buy period is in effect.

NRND: Not recommended for new designs. Device is in production to support existing customers, but TI does not recommend using this part in a new design.

PREVIEW: Device has been announced but is not in production. Samples may or may not be available.

OBsolete: TI has discontinued the production of the device.

⁽²⁾ Eco Plan - The planned eco-friendly classification: Pb-Free (RoHS), Pb-Free (RoHS Exempt), or Green (RoHS & no Sb/Br) - please check <http://www.ti.com/productcontent> for the latest availability information and additional product content details.

TBD: The Pb-Free/Green conversion plan has not been defined.

Pb-Free (RoHS): TI's terms "Lead-Free" or "Pb-Free" mean semiconductor products that are compatible with the current RoHS requirements for all 6 substances, including the requirement that lead not exceed 0.1% by weight in homogeneous materials. Where designed to be soldered at high temperatures, TI Pb-Free products are suitable for use in specified lead-free processes.

Pb-Free (RoHS Exempt): This component has a RoHS exemption for either 1) lead-based flip-chip solder bumps used between the die and package, or 2) lead-based die adhesive used between the die and leadframe. The component is otherwise considered Pb-Free (RoHS compatible) as defined above.

Green (RoHS & no Sb/Br): TI defines "Green" to mean Pb-Free (RoHS compatible), and free of Bromine (Br) and Antimony (Sb) based flame retardants (Br or Sb do not exceed 0.1% by weight in homogeneous material)

⁽³⁾ MSL, Peak Temp. -- The Moisture Sensitivity Level rating according to the JEDEC industry standard classifications, and peak solder temperature.

Important Information and Disclaimer:The information provided on this page represents TI's knowledge and belief as of the date that it is provided. TI bases its knowledge and belief on information provided by third parties, and makes no representation or warranty as to the accuracy of such information. Efforts are underway to better integrate information from third parties. TI has taken and continues to take reasonable steps to provide representative and accurate information but may not have conducted destructive testing or chemical analysis on incoming materials and chemicals. TI and TI suppliers consider certain information to be proprietary, and thus CAS numbers and other limited information may not be available for release.

In no event shall TI's liability arising out of such information exceed the total purchase price of the TI part(s) at issue in this document sold by TI to Customer on an annual basis.

TAPE AND REEL INFORMATION



QUADRANT ASSIGNMENTS FOR PIN 1 ORIENTATION IN TAPE



*All dimensions are nominal

Device	Package Type	Package Drawing	Pins	SPQ	Reel Diameter (mm)	Reel Width W1 (mm)	A0 (mm)	B0 (mm)	K0 (mm)	P1 (mm)	W (mm)	Pin1 Quadrant
THS7318YZFR	DSBGA	YZF	9	3000	180.0	8.4	1.65	1.65	0.81	4.0	8.0	Q1
THS7318YZFT	DSBGA	YZF	9	250	180.0	8.4	1.65	1.65	0.81	4.0	8.0	Q1

TAPE AND REEL BOX DIMENSIONS



*All dimensions are nominal

Device	Package Type	Package Drawing	Pins	SPQ	Length (mm)	Width (mm)	Height (mm)
THS7318YZFR	DSBGA	YZF	9	3000	220.0	220.0	34.0
THS7318YZFT	DSBGA	YZF	9	250	220.0	220.0	34.0

YZF (S-XBGA-N9)

DIE-SIZE BALL GRID ARRAY

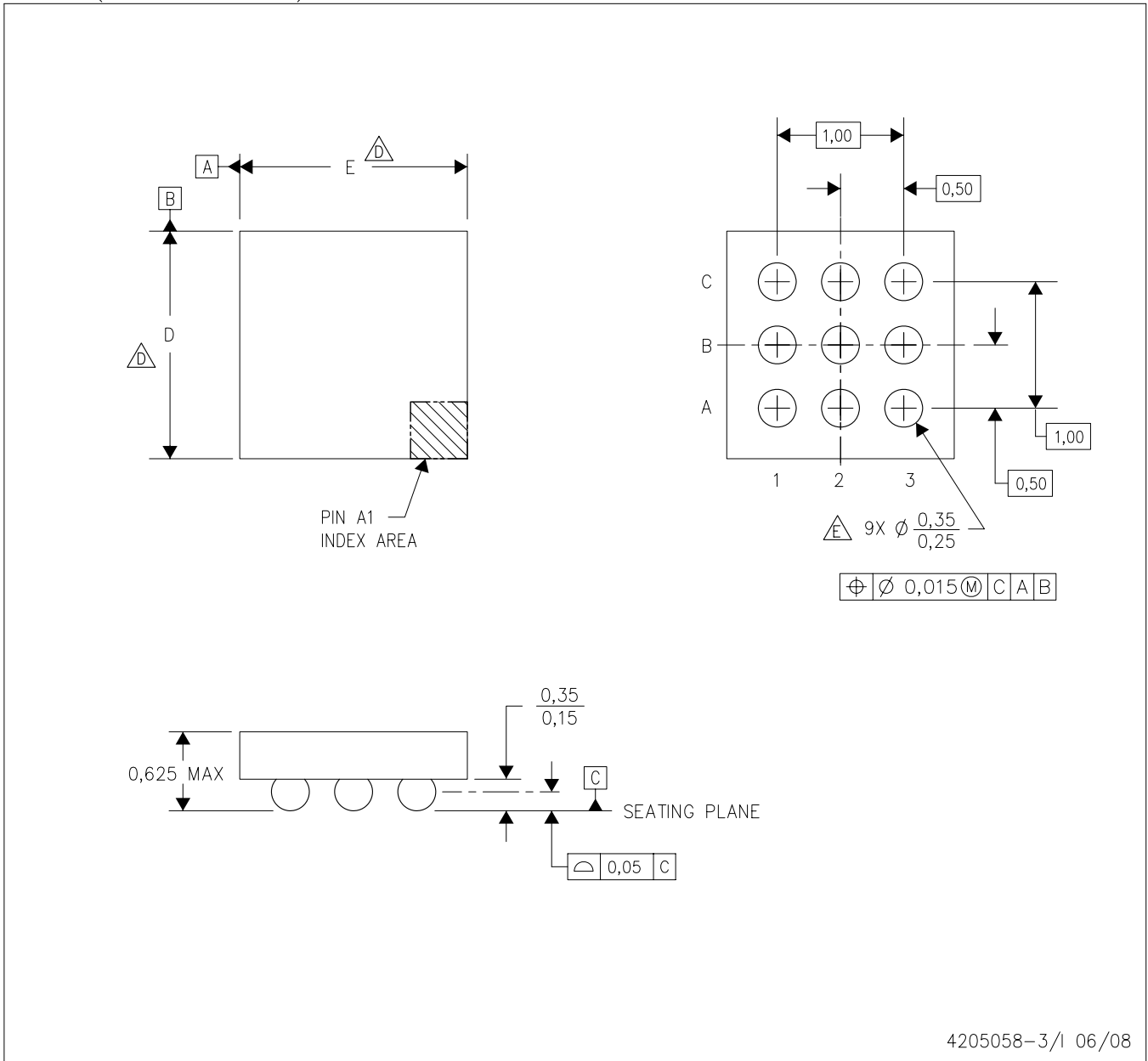

- NOTES:
- A. All linear dimensions are in millimeters.
 - B. This drawing is subject to change without notice.
 - C. NanoFree™ package configuration.
 - \triangle Devices in YZF package can have dimension D ranging from 1.44 to 2.15 mm and dimension E ranging from 1.44 to 2.15 mm. To determine the exact package size of a particular device, refer to the device datasheet or contact a local TI representative.
 - E. Reference Product Data Sheet for array population.
3 x 3 matrix pattern is shown for illustration only.
 - F. This package contains lead-free balls.
Refer to YEF (Drawing #4204181) for tin-lead (SnPb) balls.

NanoFree is a trademark of Texas Instruments.

IMPORTANT NOTICE

Texas Instruments Incorporated and its subsidiaries (TI) reserve the right to make corrections, modifications, enhancements, improvements, and other changes to its products and services at any time and to discontinue any product or service without notice. Customers should obtain the latest relevant information before placing orders and should verify that such information is current and complete. All products are sold subject to TI's terms and conditions of sale supplied at the time of order acknowledgment.

TI warrants performance of its hardware products to the specifications applicable at the time of sale in accordance with TI's standard warranty. Testing and other quality control techniques are used to the extent TI deems necessary to support this warranty. Except where mandated by government requirements, testing of all parameters of each product is not necessarily performed.

TI assumes no liability for applications assistance or customer product design. Customers are responsible for their products and applications using TI components. To minimize the risks associated with customer products and applications, customers should provide adequate design and operating safeguards.

TI does not warrant or represent that any license, either express or implied, is granted under any TI patent right, copyright, mask work right, or other TI intellectual property right relating to any combination, machine, or process in which TI products or services are used. Information published by TI regarding third-party products or services does not constitute a license from TI to use such products or services or a warranty or endorsement thereof. Use of such information may require a license from a third party under the patents or other intellectual property of the third party, or a license from TI under the patents or other intellectual property of TI.

Reproduction of TI information in TI data books or data sheets is permissible only if reproduction is without alteration and is accompanied by all associated warranties, conditions, limitations, and notices. Reproduction of this information with alteration is an unfair and deceptive business practice. TI is not responsible or liable for such altered documentation. Information of third parties may be subject to additional restrictions.

Resale of TI products or services with statements different from or beyond the parameters stated by TI for that product or service voids all express and any implied warranties for the associated TI product or service and is an unfair and deceptive business practice. TI is not responsible or liable for any such statements.

TI products are not authorized for use in safety-critical applications (such as life support) where a failure of the TI product would reasonably be expected to cause severe personal injury or death, unless officers of the parties have executed an agreement specifically governing such use. Buyers represent that they have all necessary expertise in the safety and regulatory ramifications of their applications, and acknowledge and agree that they are solely responsible for all legal, regulatory and safety-related requirements concerning their products and any use of TI products in such safety-critical applications, notwithstanding any applications-related information or support that may be provided by TI. Further, Buyers must fully indemnify TI and its representatives against any damages arising out of the use of TI products in such safety-critical applications.

TI products are neither designed nor intended for use in military/aerospace applications or environments unless the TI products are specifically designated by TI as military-grade or "enhanced plastic." Only products designated by TI as military-grade meet military specifications. Buyers acknowledge and agree that any such use of TI products which TI has not designated as military-grade is solely at the Buyer's risk, and that they are solely responsible for compliance with all legal and regulatory requirements in connection with such use.

TI products are neither designed nor intended for use in automotive applications or environments unless the specific TI products are designated by TI as compliant with ISO/TS 16949 requirements. Buyers acknowledge and agree that, if they use any non-designated products in automotive applications, TI will not be responsible for any failure to meet such requirements.

Following are URLs where you can obtain information on other Texas Instruments products and application solutions:

Products

Amplifiers	amplifier.ti.com
Data Converters	dataconverter.ti.com
DSP	dsp.ti.com
Clocks and Timers	www.ti.com/clocks
Interface	interface.ti.com
Logic	logic.ti.com
Power Mgmt	power.ti.com
Microcontrollers	microcontroller.ti.com
RFID	www.ti-rfid.com
RF/IF and ZigBee® Solutions	www.ti.com/lprf

Applications

Audio	www.ti.com/audio
Automotive	www.ti.com/automotive
Broadband	www.ti.com/broadband
Digital Control	www.ti.com/digitalcontrol
Medical	www.ti.com/medical
Military	www.ti.com/military
Optical Networking	www.ti.com/opticalnetwork
Security	www.ti.com/security
Telephony	www.ti.com/telephony
Video & Imaging	www.ti.com/video
Wireless	www.ti.com/wireless

Mailing Address: Texas Instruments, Post Office Box 655303, Dallas, Texas 75265
Copyright © 2008, Texas Instruments Incorporated